

SEVCON®

Partner with Performance



HypAC

HYDRAULIC POWER STEERING

Specifically designed to offer a brushless alternative to DC series pump systems the HypAC, brushless permanent magnet AC motor and integrated controller, provides significant performance advantages over an equivalent DC system. HypAC simplifies the path to a completely brushless vehicle design.

FEATURES

- Highly efficient brushless, maintenance free motor perfectly suited to high duty cycle applications such as hydraulic power steering.
- Soft start significantly reduces inrush currents and acceleration forces, improving battery life and mechanical reliability.
- IP54 protection
- Integrated CoolFlow thermal management ensures that the full operating specification is achieved in a +60°C ambient.
- The system can be supplied fully assembled with hydraulic pump and tank thus saving production line assembly time.
- Hydraulic load sensing for optimal power delivery and reduced audible noise.



HypAC

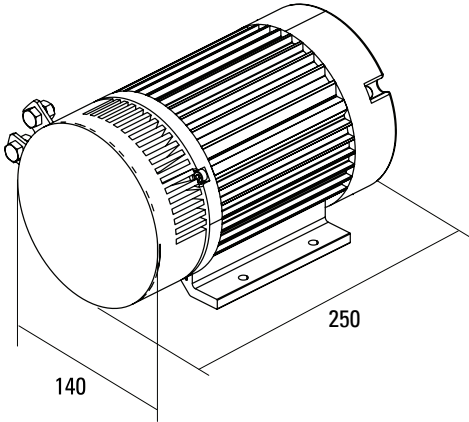

KEY PARAMETERS

Model	Voltage (VDC)	S1 (kW)
H2412	24-36	1.5
H4812	36-48	1.2
8012	72-80	1.2

ACCESSORIES

Available as a standalone HypAC unit or as a hydraulic powerpak assembly with:

- Oil tank
- Gear pump
- Pressure relief valve
- Single or dual pump options available

SIMPLE APPLICATION

Its simple interface mimics typical DC motor/contacter system. An additional fault reporting interface is available to provide operating status to a vehicle controller.

ENHANCED OPERATING MODES

Open loop mode for full speed at available battery voltage to mimic DC motor operation. Closed loop mode for fixed speed operation to give consistent performance across varying operating voltages. Load compensation mode for optimal energy efficiency and reduced system audible noise. The motor speed is automatically regulated relative to the applied load.

MECHANICAL INTERFACE

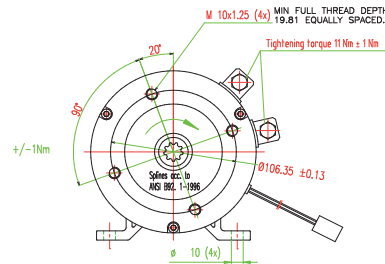

TYPICAL SPEED TORQUE PERFORMANCES (H2412 AND H4812)

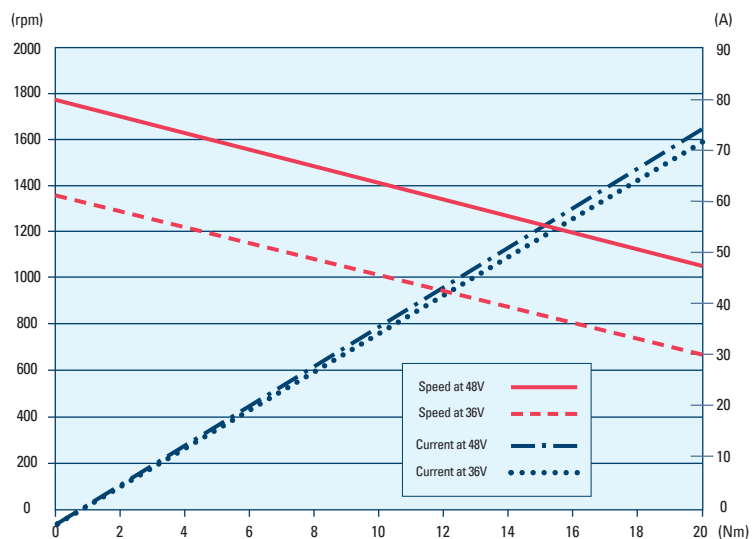

SEVCON

Partner with Performance

Sevcon Ltd Kingsway South
Gateshead NE11 0QA England
T +44 (0)191 497 9000
sales.uk@sevcon.com

Sevcon Inc 155 Northboro Road
Southborough MA01772 USA
T +1 (508) 281 5500
sales.us@sevcon.com

Sevcon SAS Parc d'Activité
du Vert Galant Rue Saint Simon
St Ouen l'Aumône
95041 Cergy Pontoise Cedex France
T +33 (0)1 34 30 35 00
sales.fr@sevcon.com

Sevcon Japan K.K.
Kansai Office 51-26 Ohayabu Hikone
Shiga Japan 522-0053
T +81 (0) 7 49465766
jp.info@sevcon.com

Sevcon Asia Ltd
Room No.202 Dong-Ah Heights Bldg
449-1 Sang-Dong Wonmi-Gu
Bucheon City Gyeonggi-Do
420-816 Korea
T +82 32 215 5070
sales.kr@sevcon.com

Sevcon Germany
Hintere Str.32
73266 Bissingen an der Teck
Germany
T: +49 (0)170 9980294
E: de.info@sevcon.com

follow @Sevcon
www.sevcon.com